

DWG. NO.	BBLZ-4/OS	REV.
		-

METAL STAMP TO READ:

1. 4/0
2. CU
3. S
4. "STUD HOLE"
5. DB
6. 
7. 

REV.	CAT. NO.	STUD HOLE	DIMENSIONS					APPROX. WEIGHT (LB)	STRIP LENGTH
			A	B	C	D	E		
-	BBLZ-4/OS	1/2	3.31	1.25	1.63	.14	1.00	0.134	1.75

USE BELOW OPTIONAL SUFFIXES FOR ALTERNATE LUG CONFIGURATIONS:
 -45 FOR 45° BENT PAD
 -90 FOR 90° BENT PAD
 -FL FOR FLARED BARREL ENTRY
 -U FOR UNDRILLED PAD
 EXAMPLE: BBLZ-4/OS-FL

INK STAMP REFERENCE

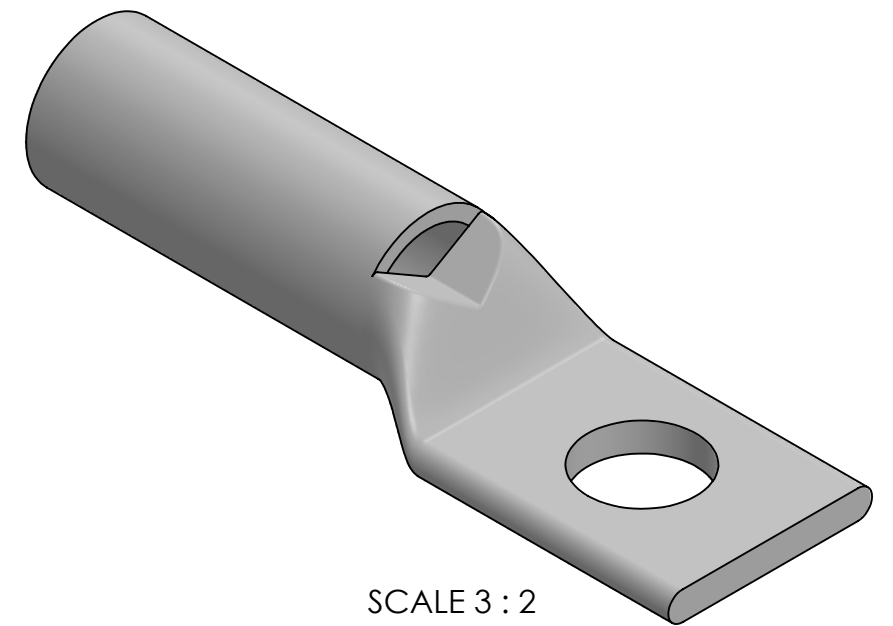
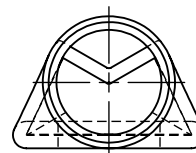
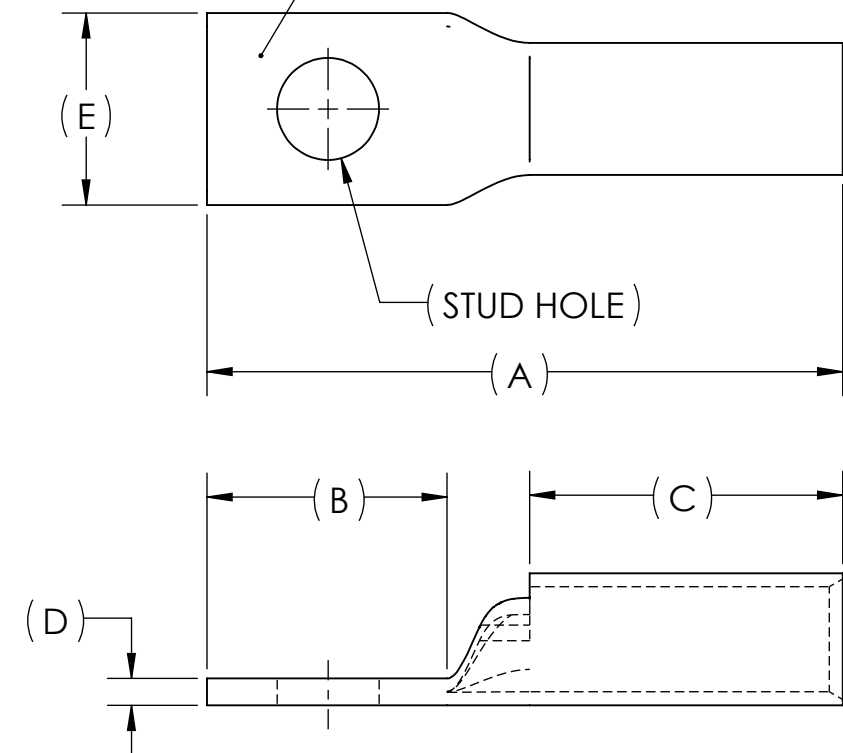

SCALE 3 : 2

NOTES:

1. ALL DIMENSIONS IN INCHES UNLESS OTHERWISE SPECIFIED
2. SEE INSTALLATION SHEET FOR WIRE SIZE AND TOOLING RECOMMENDATIONS
3. TIN-PLATED TO INHIBIT CORROSION
4. RATED FOR COPPER CONDUCTORS ONLY
5. BEVELED ENTRY FOR EASY CABLE INSERTION
6. INSPECTION WINDOW TO ENSURE FULL CABLE INSERTION
7. CONNECTORS ARE SUITABLE FOR VOLTAGES UP TO 35 KV
8. FOR APPLICATIONS GREATER THAN 2000 VOLTS, CONSULT CABLE MANUFACTURER FOR VOLTAGE STRESS RELIEF INSTRUCTIONS
9. CONNECTORS ARE UL LISTED PER UL486A-B AND CSA CERTIFIED PER C22.2 NO.65 FOR POWER APPLICATIONS UP TO 90°C
10. CONNECTORS ARE UL LISTED FOR GROUNDING, BONDING, AND DIRECT BURIAL APPLICATIONS PER UL467
11. CONNECTORS ARE CSA CERTIFIED FOR GROUNDING, BONDING, AND DIRECT BURIAL APPLICATIONS PER C22.2 NO.41



NO.	ECN	DATE
REVISIONS		

		X		COPPER TUBING	
QTY.		PT.		NAME OR DESCRIPTION	
				PENN-CRIMP LUG	
				for	
				4/0 AWG COPPER CONDUCTORS	
		REF. DWG'S: 2H02-55742		H:\2H02\BBLZ-4.0S	
		DRAWN BY: DT		DATE: 6/1/2023	
		SCALE: 1:1		INTERPRET PER ASME Y14.5-2009	
		SIZE: B		FILE: 2H02	
		DWG. NO. BBLZ-4/OS		REV. -	
		SEE TABLE		CAT. NO.	
		PENNUNION™		229 WATERFORD STREET EDINBORO, PA 16412 USA	