

DWG. NO. **BLU-2S-NT** REV. -

CAT. NO.	SUFFIX	STUD HOLE	DIMENSIONS					APPROX. WEIGHT (LB)	STRIP LENGTH
			A	B	C	D	E		
BLU-2S15-NT	S15-NT	#10	1.85	.69	.88	.13	.50	0.035	1.00
BLU-2S-NT	S-NT	1/4	1.85	.69	.88	.13	.50	0.034	
BLU-2S1-NT	S1-NT	5/16	1.91	.75	.88	.13	.50	0.034	

METAL STAMP TO READ:

1. 2
2. CU
3. "SUFFIX"
4. "STUD HOLE"
5. DB
6. 
7. 

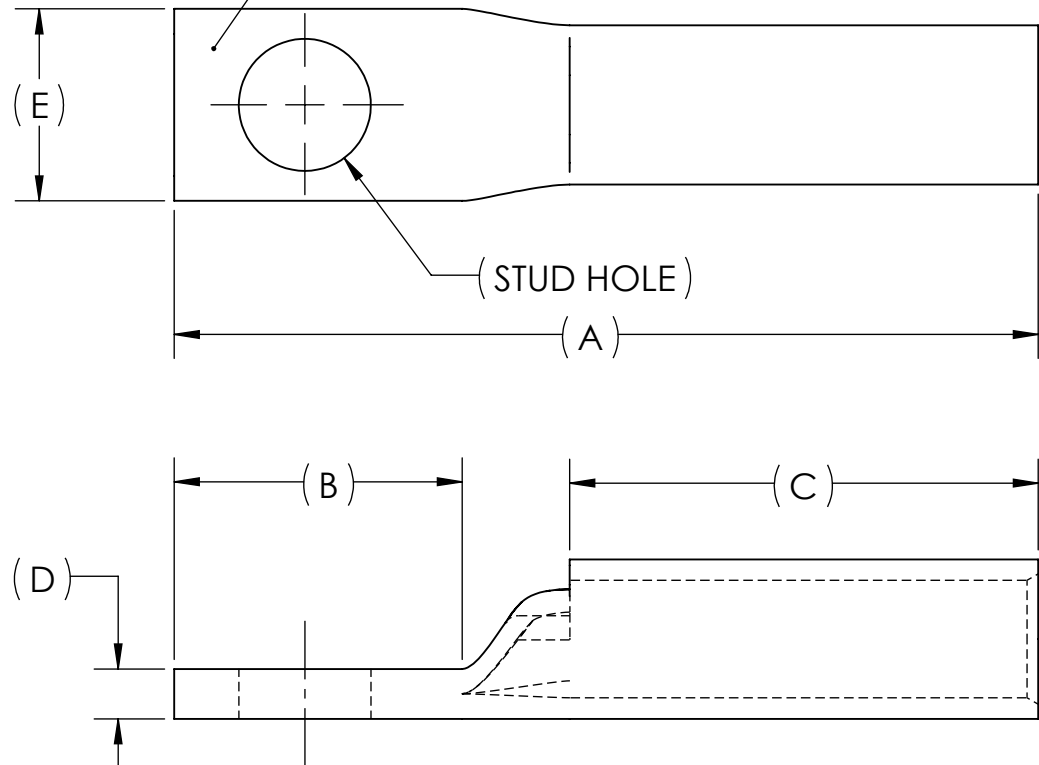

INK STAMP REFERENCE

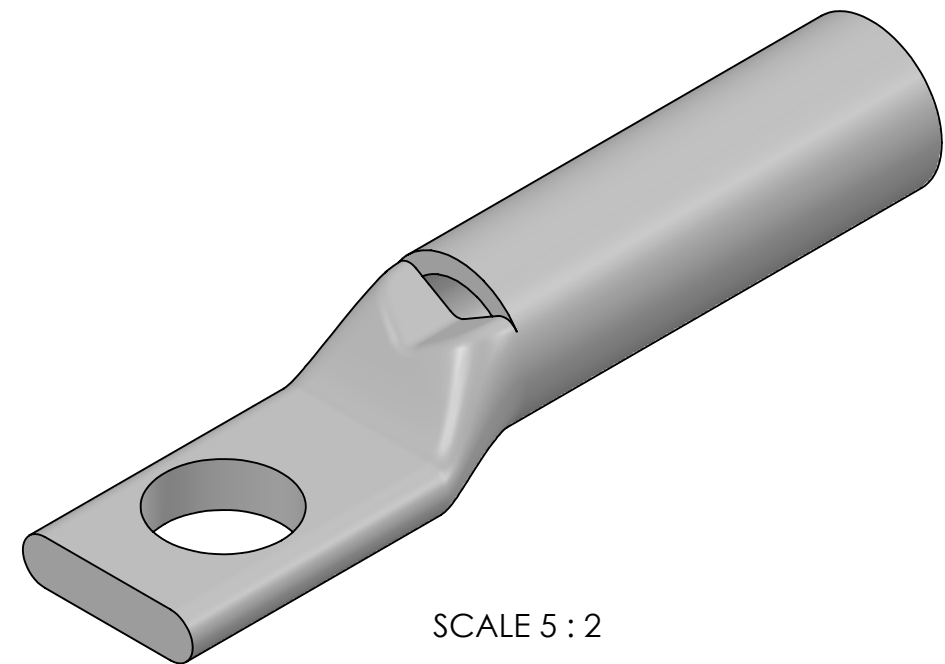
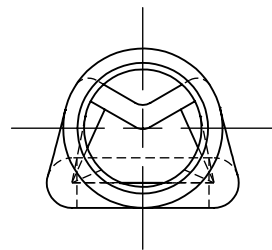
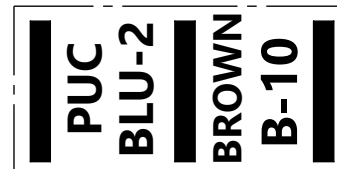

SCALE 5 : 2

NOTES:

1. ALL DIMENSIONS IN INCHES UNLESS OTHERWISE SPECIFIED
2. SEE INSTALLATION SHEET FOR WIRE SIZE AND TOOLING RECOMMENDATIONS
3. TIN-PLATED TO INHIBIT CORROSION
4. RATED FOR COPPER CONDUCTORS ONLY
5. BEVELED ENTRY FOR EASY CABLE INSERTION
6. INSPECTION WINDOW TO ENSURE FULL CABLE INSERTION
7. CONNECTORS ARE SUITABLE FOR VOLTAGES UP TO 35 KV
8. FOR APPLICATIONS GREATER THAN 2000 VOLTS, CONSULT CABLE MANUFACTURER FOR VOLTAGE STRESS RELIEF INSTRUCTIONS
9. CONNECTORS ARE UL LISTED PER UL486A-B AND CSA CERTIFIED PER C22.2 NO.65 FOR POWER APPLICATIONS UP TO 90°C
10. CONNECTORS ARE UL LISTED FOR GROUNDING, BONDING, AND DIRECT BURIAL APPLICATIONS PER UL467
11. CONNECTORS ARE CSA CERTIFIED FOR GROUNDING, BONDING, AND DIRECT BURIAL APPLICATIONS PER C22.2 NO.41



NO.	ECN	DATE
REVISIONS		

QTY.	PT.	NAME OR DESCRIPTION
	X	COPPER TUBING
		LONG BARREL NARROW TONGUE LUG for 2 AWG COPPER CONDUCTORS
REF. DWG'S: 2H03-56171		H:\2H03\BLU-2S-NT
DRAWN BY: DT		DATE: 7/5/2023
SCALE: 2:1		CHK'D: QJB
SIZE: B		INTERPRET PER ASME Y14.5-2009
DWG. NO. <b>BLU-2S-NT</b>		FILE: 2H03
229 WATERFORD STREET EDINBORO, PA 16412 USA		REV. -