

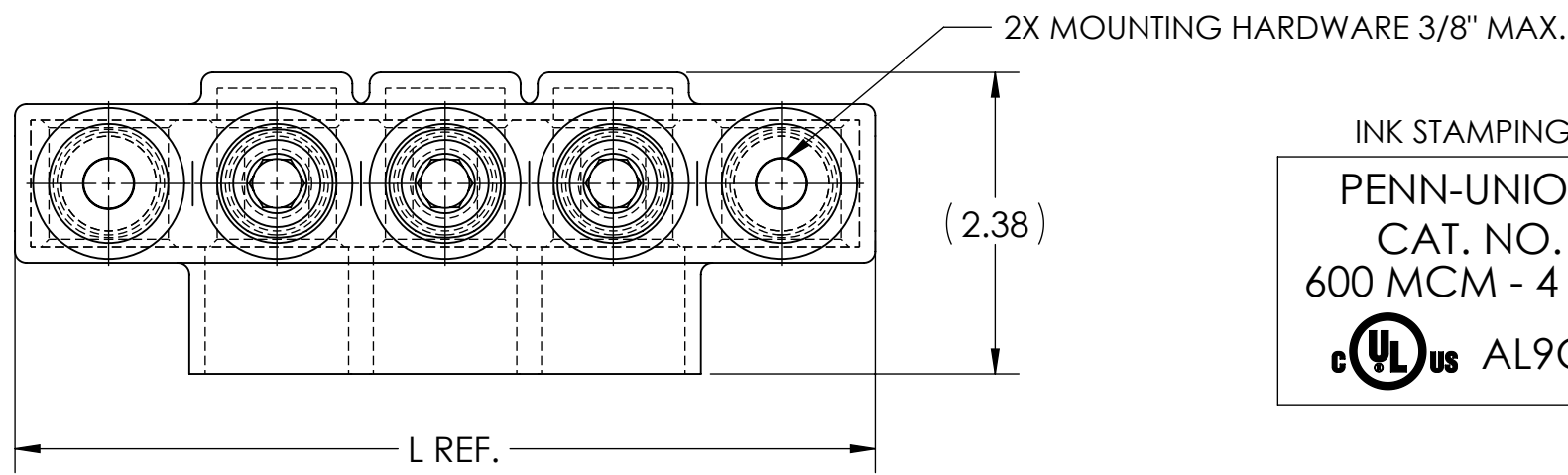

DWG. NO. **IPBM-NA600-S** REV. **4**

- NOTES:
1. ALL DIMENSIONS IN INCHES UNLESS OTHERWISE SPECIFIED
 2. CONDUCTOR RANGE: 600 MCM - 4 STR
 3. DESIGNED FOR APPLICATIONS WHERE SECURE MOUNTING OF CONNECTOR IS REQUIRED
 4. SUITABLE FOR USE IN PANEL BOARDS, CABLE TRAYS, RACEWAYS, DUCTS, AND TROUGHS
 5. INSULATION TEMPERATURE RATING: 135°C TO -40°C
 6. PRE-FILLED WITH OXIDE INHIBITOR
 7. SUPPLIED WITH REMOVABLE ACCESS PLUGS
 8. PRE-INSULATED WITH CLEAR HIGH DIELECTRIC STRENGTH PLASTISOL
 9. HEX SIZE: 3/8"
 10. INSTALLATION TORQUE: 400 IN•LB

11.  LISTED TO 486A-486B FOR ALUMINUM AND COPPER CONDUCTORS AT 90°C
12. CONNECTORS ARE RATED AND LISTED FOR PARALLEL USE. PLEASE SEE PARALLEL RATING SHEET FOR SPECIFIC INFORMATION



INK STAMPING:
PENN-UNION
CAT. NO.
600 MCM - 4 STR
 **AL9CU**

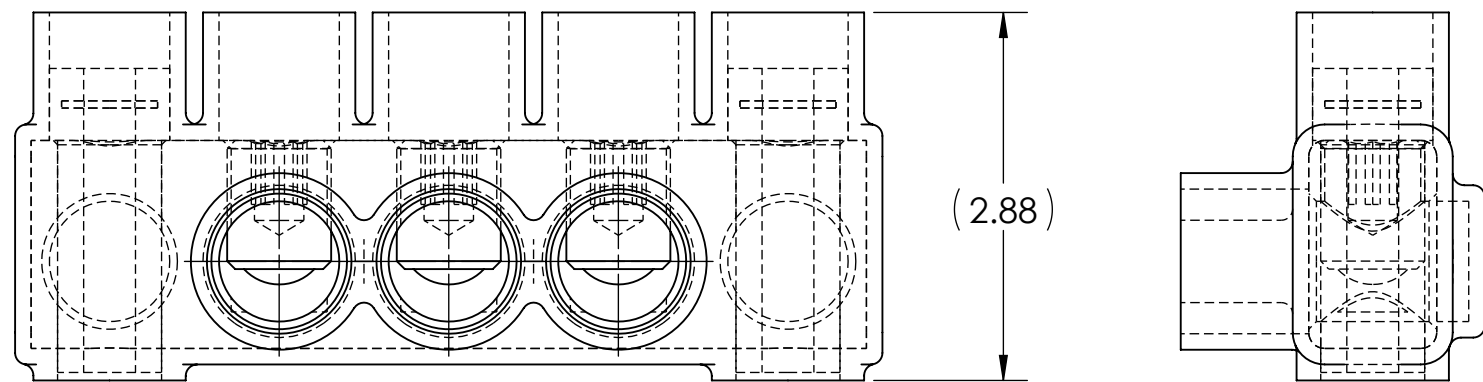

CAT. NO.	L REF.	N	NUMBER OF CONDUCTORS	APPROX. WEIGHT (LB)
IPBM-NA600-2S	5.45	2	2	0.866
IPBM-NA600-3S	6.78	3	3	1.099
IPBM-NA600-4S	8.10	4	4	1.326
IPBM-NA600-5S	9.43	5	5	1.556
IPBM-NA600-6S	10.75	6	6	1.787
IPBM-NA600-8S	13.40	8	8	2.247
IPBM-NA600-10S	16.05	10	10	2.707
IPBM-NA600-12S	18.70	12	12	3.167

- NOTES:
1. APPROX. WEIGHT EXCLUDES ITEMS 3 AND 4
 2. CONDUCTOR PORTS ARE "N" QUANTITY, VIEWS BELOW ARE FOR REFERENCE ONLY

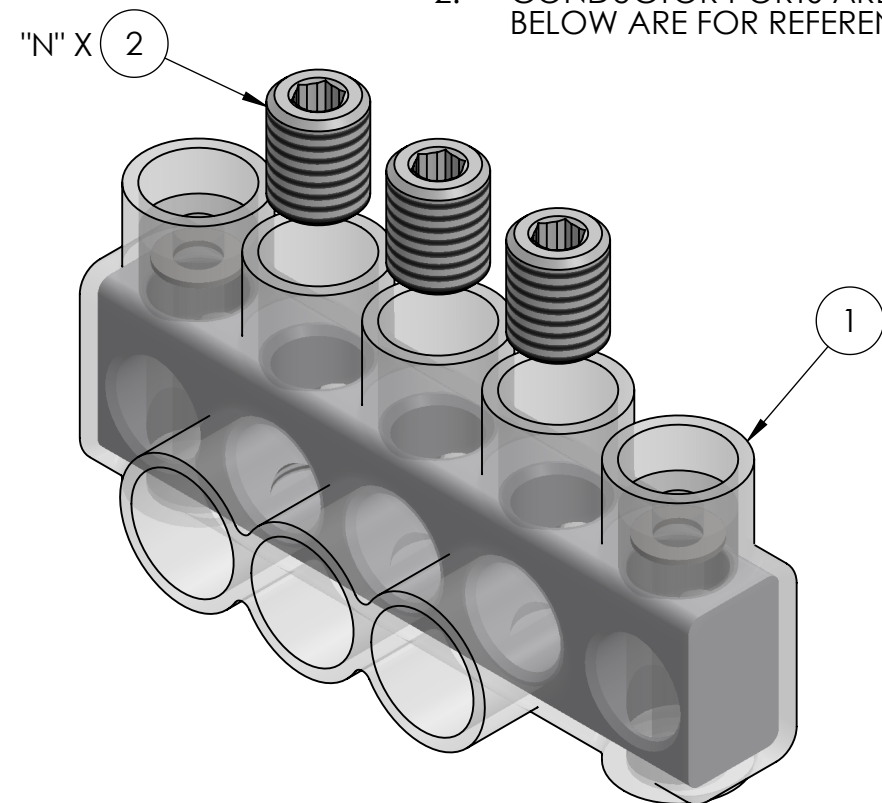

RoHS
COMPLIANT

CONDUCTOR SIZE AND STRANDING					
CLASS B & C	CLASS G	CLASS H	CLASS I	CLASS K	DIESEL LOCOMOTIVE CABLE (DLO)
600 MCM - 4 STR.	350 MCM (259/.0368) - #4 (49/.0292)	350 MCM (427/.0286) - #4 (133/.0177)	350 MCM (882/.0201) - #4 (105/.0201)	350 MCM (3458/.0100) - #4 (420/.0100)	373 MCM (925/.0201) - #4 (105/.0201)

NO.	ECN	DATE
4	11908	1/2/2020
3	11841	4/2/2019
2	11675	12/20/2016
1	11576	6/19/2015

QTY.	PT.	NAME OR DESCRIPTION
	2N	4 PLASTIC PLUG (NOT SHOWN)
	X	3 CUAL-GEL OXIDE INHIBITOR (NOT SHOWN)
	N	2 ALUMINUM SET SCREW
	1	1 INSULATED ALUMINUM BODY
CLEAR INSULATED MOUNTABLE POWER BAR for 600 MCM - 4 STR		
REF. DWG'S: 4304-55777S7		H:\4304\55777S7_C
 229 WATERFORD STREET EDINBORO, PA 16412 USA		DRAWN BY: QJB DATE: 6/15/2021 CHK'D: CLT
		SCALE: 2:3 INTERPRET PER ASME Y14.5-2009 FILE: 4304
SEE TABLE	CAT. NO.	DWG. IPBM-NA600-S REV. 4