

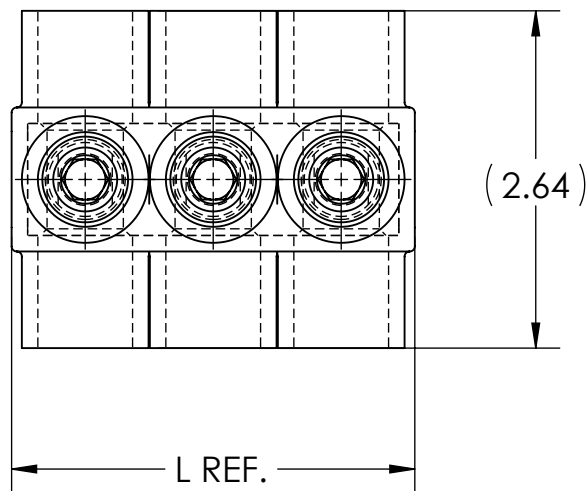

DWG. NO. **IPB-NA250-D** REV. **1**

- NOTES:
1. ALL DIMENSIONS IN INCHES UNLESS OTHERWISE SPECIFIED
 2. CONDUCTOR RANGE: 250 MCM - 10 SOL
 3. SUITABLE FOR USE IN PANEL BOARDS, CABLE TRAYS, RACEWAYS, DUCTS, AND TROUGHS
 4. INSULATION TEMPERATURE RATING: 135°C TO -40°C
 5. PRE-FILLED WITH OXIDE INHIBITOR
 6. SUPPLIED WITH REMOVABLE ACCESS PLUGS
 7. PRE-INSULATED WITH CLEAR HIGH DIELECTRIC STRENGTH PLASTISOL
 8. HEX SIZE: 5/16"
 9. INSTALLATION TORQUE: 275 IN•LB

10.  LISTED TO 486A-486B FOR ALUMINUM AND COPPER CONDUCTORS AT 90°C
11. CONNECTORS ARE RATED AND LISTED FOR PARALLEL USE. PLEASE SEE PARALLEL RATING SHEET FOR SPECIFIC INFORMATION



INK STAMPING:
 PENN-UNION
 CAT. NO.
 250 MCM - 10 SOL
 AL9CU

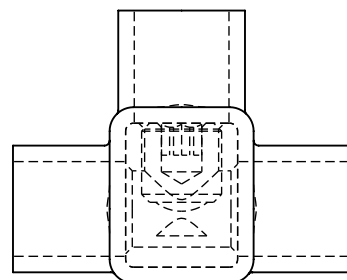
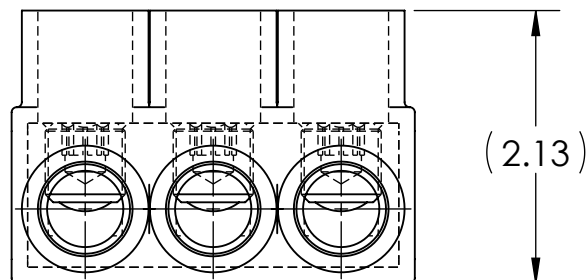

CAT. NO.	L REF.	N	NUMBER OF CONDUCTORS	APPROX. WEIGHT (LB)
IPB-NA250-2D	2.15	2	2	0.255
IPB-NA250-3D	3.15	3	3	0.381
IPB-NA250-4D	4.15	4	4	0.506
IPB-NA250-5D	5.15	5	5	0.639
IPB-NA250-6D	6.15	6	6	0.757
IPB-NA250-8D	8.15	8	8	1.007
IPB-NA250-10D	10.15	10	10	1.258
IPB-NA250-12D	12.15	12	12	1.509
IPB-NA250-14D	14.15	14	14	1.760

- NOTES:
1. APPROX. WEIGHT EXCLUDES ITEMS 3 AND 4
 2. CONDUCTOR PORTS ARE "N" QUANTITY, VIEWS BELOW ARE FOR REFERENCE ONLY

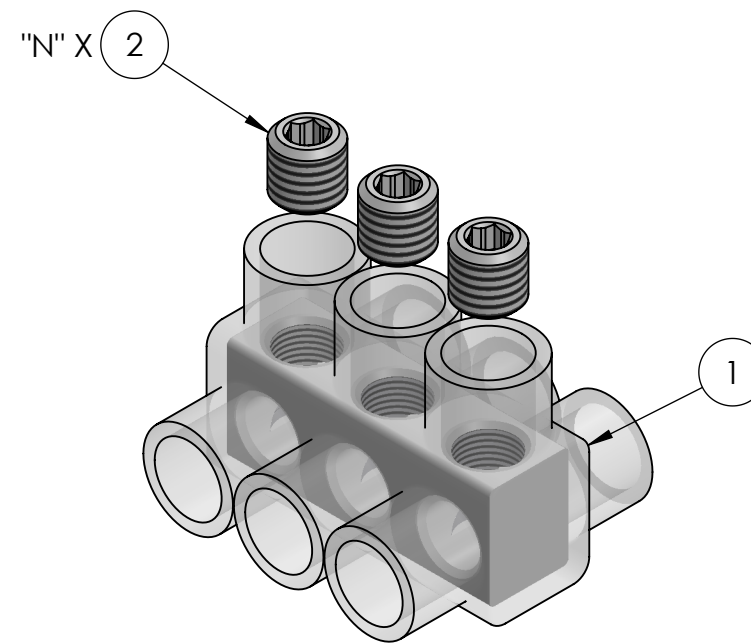

RoHS
COMPLIANT

CONDUCTOR SIZE AND STRANDING					
CLASS B & C	CLASS G	CLASS H	CLASS I	CLASS K	DIESEL LOCOMOTIVE CABLE (DLO)
250 MCM - 10 SOL.	3/0 (133/.0355) - #10 (49/.0146)	3/0 (259/.0255) - #9 (133/.0099)	3/0 (418/.0201) - #6 (63/.0201)	3/0 (1666/.0100) - #9 (133/.0100)	3/0 (450/.0201) - #10 (27/.0201)

NO.	ECN	DATE
1	11881	12/27/2019

QTY.	PT.	NAME OR DESCRIPTION
	3N	4 PLASTIC PLUG (NOT SHOWN)
	X	3 CUAL GEL OXIDE INHIBITOR (NOT SHOWN)
	N	2 ALUMINUM SET SCREW
	1	1 INSULATED ALUMINUM BODY
CLEAR INSULATED POWER BAR for 250 MCM - 10 SOL		
REF. DWG'S: 4304-98197S2		H:\4304\98197S2_C
		DRAWN BY: QJB DATE: 6/9/2021 CHK'D: CLT
229 WATERFORD STREET EDINBORO, PA 16412 USA		SCALE: 2:3 INTERPRET PER ASME Y14.5-2009 FILE: 4304
SEE TABLE	CAT. NO.	DWG. NO. IPB-NA250-D REV. 1