

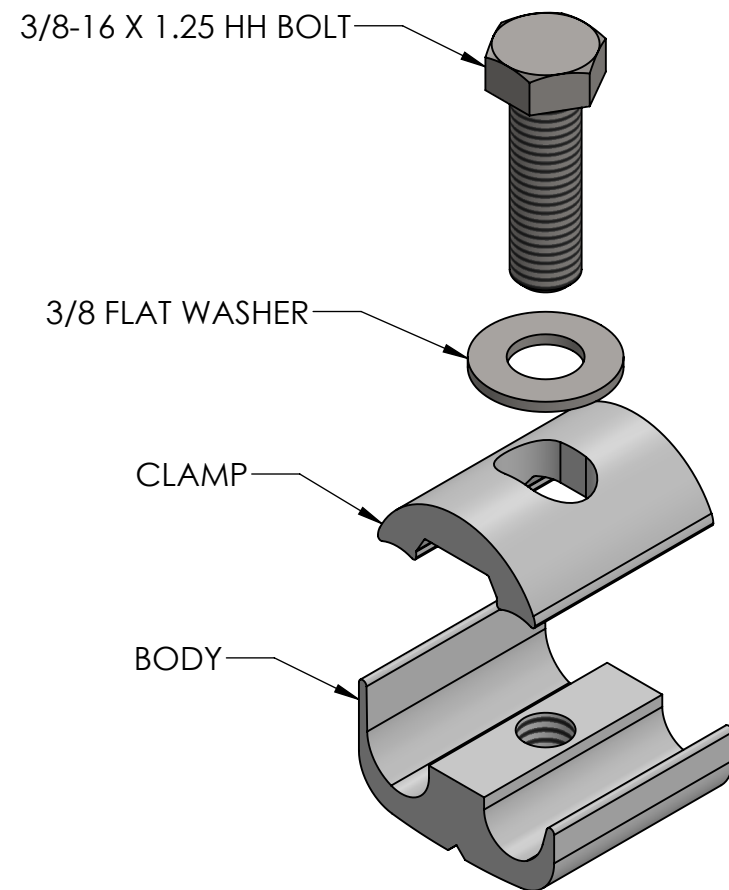

SEE NOTE 7.1

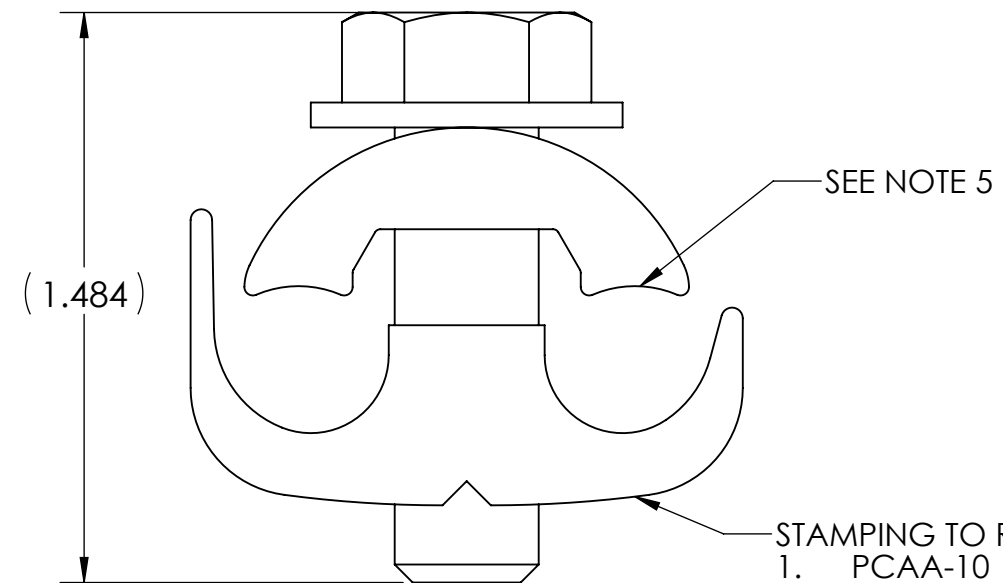

SCALE 1 : 1

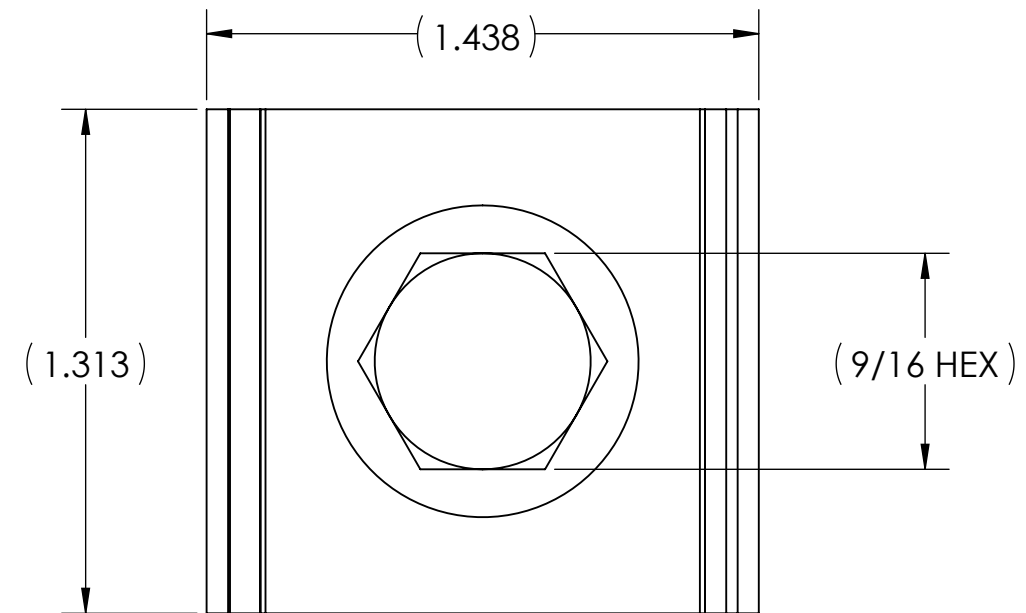

STAMPING TO READ:  
 1. PCAA-10  
 2. 6 SOL. TO 1/0 ACSR  
 3. PENN-UNION

CONDUCTOR RANGE		INSTALLATION TORQUE
MAIN	TAP	
6 SOL.-1/0 STR. 6-1/0 ACSR	6 SOL.-1/0 STR. 6-1/0 ACSR	240 IN•LB

NOTE:

- MANUFACTURED FROM HIGH STRENGTH ALUMINUM EXTRUDED ALLOY
- FOR ALUMINUM, COPPER AND ACSR CONDUCTORS
- DESIGNED FOR TAP AND PARALLEL CONNECTIONS
- ASSEMBLED WITH HIGH STRENGTH STAINLESS STEEL BOLTS AND FLAT WASHERS
- ALL CONDUCTOR CONTACT SURFACES HAVE SERRATED GROVES TO PROVIDE INCREASED CONDUCTOR CONTACT AND IMPROVE MECHANICAL PERFORMANCE
- FOR ALUMINUM TO COPPER APPLICATIONS, IT IS RECOMMENDED TO INSTALL THE ALUMINUM CONDUCTOR ABOVE THE COPPER CONDUCTOR TO MINIMIZE CORROSION
- FOR FACTORY APPLIED OXIDE INHIBITOR, SUFFIX CATALOG NUMBER WITH "-BF"  
 1. RUS ACCEPTED ONLY WITH SUFFIX "BF"
- FOR TIN PLATING ON BODY AND CLAMP, SUFFIX CATALOG NUMBER WITH "-TN"
- CONFORMS TO ANSI C119.4, CLASS AA CURRENT, CLASS 3 TENSION WHEN PROPERLY INSTALLED
- ALL DIMENSIONS IN INCHES UNLESS OTHERWISE SPECIFIED
- APPROX. WEIGHT: 0.148 LB

NO.	ECN	DATE
REVISIONS		

QTY.	PT.	NAME OR DESCRIPTION
		ALUM. PARALLEL CLAMP ASS'Y
REF. DWG'S: 5E16-97149		H:\H:\5E16\97149_C
DRAWN BY: QJB		DATE: 2/8/2023
SCALE: 2:1		INTERPRET PER ASME Y14.5-2009
SIZE: B		FILE: 5E16
DWG. NO. PCAA-10		REV. -
229 WATERFORD STREET EDINBORO, PA 16412 USA		