

SCALE 2 : 3

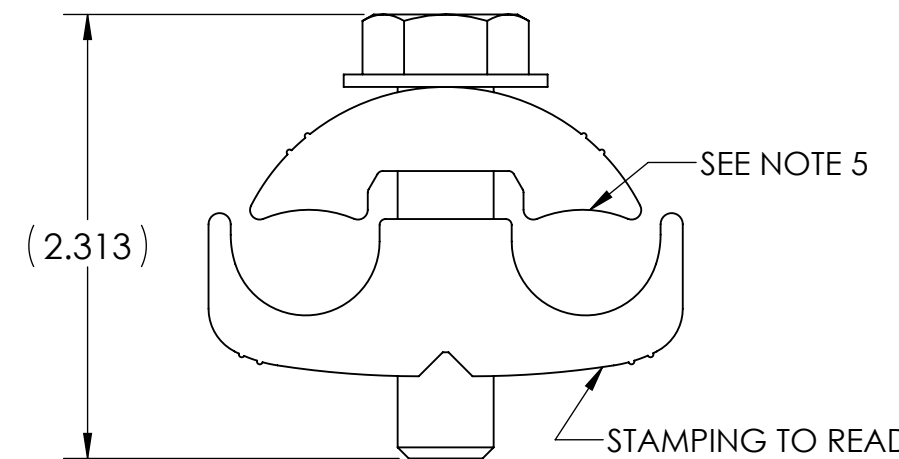
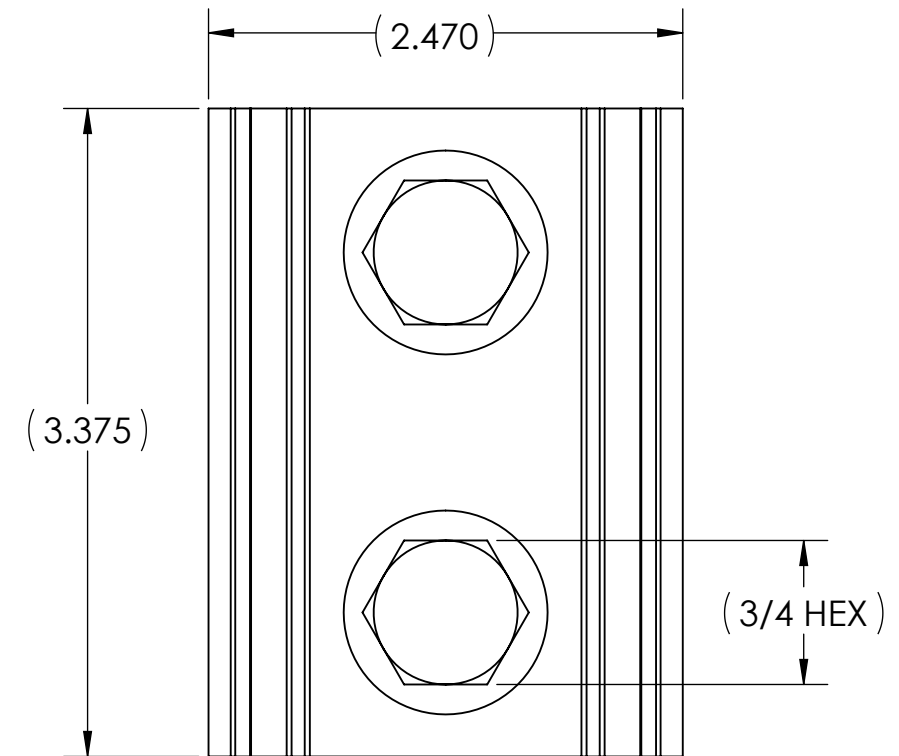

- STAMPING TO READ:
1. PCAA-23
  2. 3/0 STR. TO 397.5 18/1 ACSR
  3. PENN-UNION

CONDUCTOR RANGE		INSTALLATION TORQUE
MAIN	TAP	
3/0 STR.-400 MCM 3/0-397.5 18/1 ACSR 4-2/0 STR. AR	3/0 STR.-400 MCM 3/0-397.5 18/1 ACSR 4-2/0 STR. AR	480 IN•LB

NOTE:

1. MANUFACTURED FROM HIGH STRENGTH ALUMINUM EXTRUDED ALLOY
2. FOR ALUMINUM, COPPER, ACSR, AND AR CONDUCTORS
  1. ALL ALUMINUM CABLE RATING WITH PREFORMED ARMOR RODS
3. DESIGNED FOR TAP AND PARALLEL CONNECTIONS
4. ASSEMBLED WITH HIGH STRENGTH STAINLESS STEEL BOLTS AND FLAT WASHERS
5. ALL CONDUCTOR CONTACT SURFACES HAVE SERRATED GROVES TO PROVIDE INCREASED CONDUCTOR CONTACT AND IMPROVE MECHANICAL PERFORMANCE
6. FOR ALUMINUM TO COPPER APPLICATIONS, IT IS RECOMMENDED TO INSTALL THE ALUMINUM CONDUCTOR ABOVE THE COPPER CONDUCTOR TO MINIMIZE CORROSION
7. FOR FACTORY APPLIED OXIDE INHIBITOR, SUFFIX CATALOG NUMBER WITH "-BF"
8. FOR TIN PLATING ON BODY AND CLAMP, SUFFIX CATALOG NUMBER WITH "-TN"
9. CONFORMS TO ANSI C119.4, CLASS AA CURRENT, CLASS 3 TENSION WHEN PROPERLY INSTALLED
10. ALL DIMENSIONS IN INCHES UNLESS OTHERWISE SPECIFIED
11. APPROX. WEIGHT: 0.962 LB

NO.	ECN	DATE
REVISIONS		

QTY.	PT.	NAME OR DESCRIPTION
		ALUM. PARALLEL CLAMP ASS'Y
REF. DWG'S: 5E16-97154		H:\H:\5E16\97154_C
DRAWN BY: QJB		DATE: 2/15/2023
SCALE: 1:1		CHK'D: /AK
SIZE: B		INTERPRET PER ASME Y14.5-2009
FILE: 5E16		
PCAA-23	CAT. NO.	DWG. NO. <b>PCAA-23</b>
229 WATERFORD STREET EDINBORO, PA 16412 USA		REV. -