

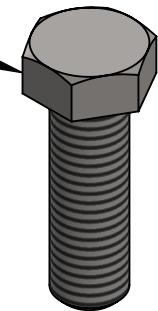

5/8-11 X 2 HH BOLT

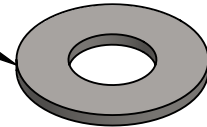

5/8 FLAT WASHER



CLAMP

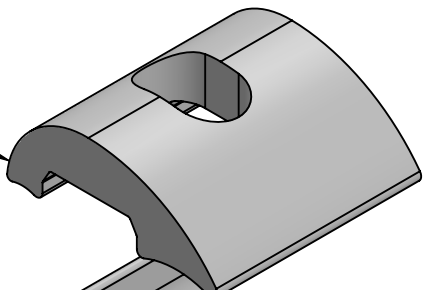

BODY

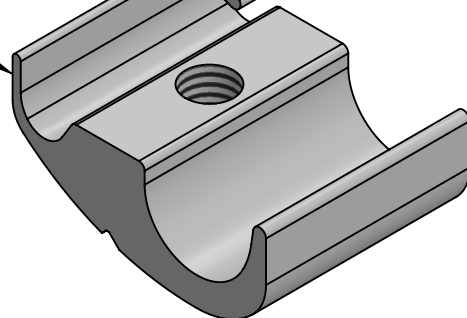

SCALE 2 : 3

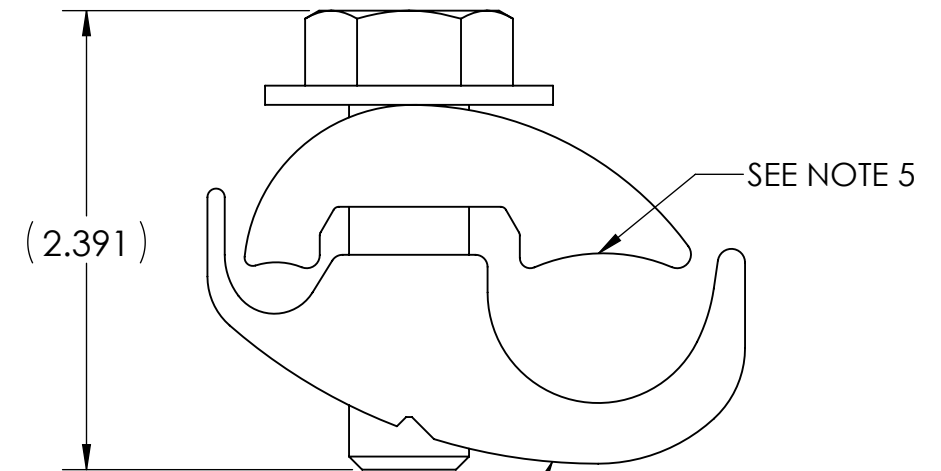
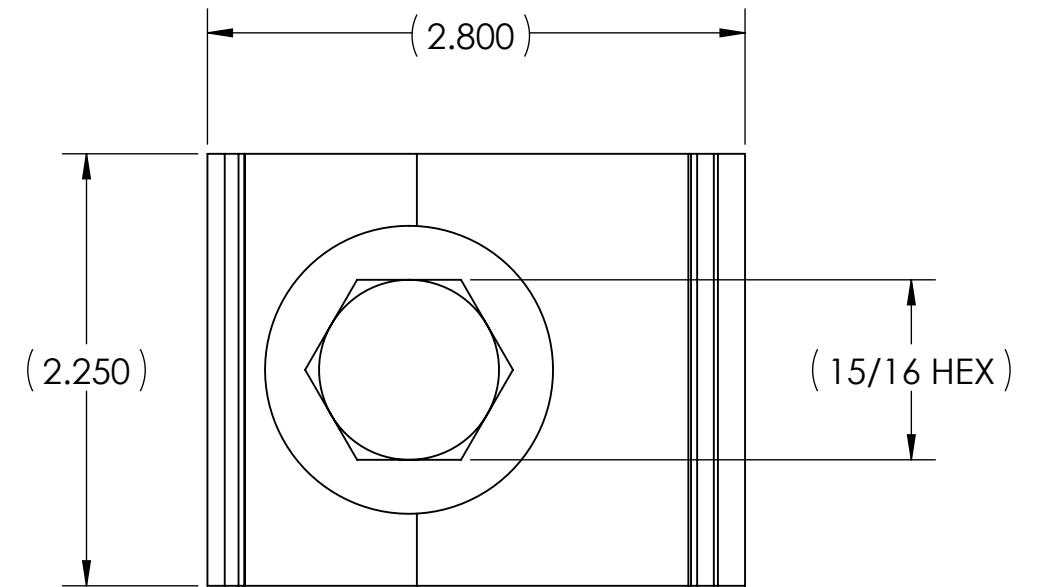

- STAMPING TO READ:
1. PCAA-27
 2. 397.5 18/2 ACSR TO 1000 MCM
 3. PENN-UNION
 4. 6 SOL. TO 2/0 STR.

CONDUCTOR RANGE		INSTALLATION TORQUE
MAIN	TAP	
400-1000 MCM 397.5 18/1 -795 ACSR 3/0 STR. -397.5 AR	6 SOL.-2/0 STR. 6-2/0 ACSR 6 STR. AR	660 IN•LB

NOTE:

1. MANUFACTURED FROM HIGH STRENGTH ALUMINUM EXTRUDED ALLOY
2. FOR ALUMINUM, COPPER, ACSR, AND AR CONDUCTORS
 1. ALL ALUMINUM CABLE RATING WITH PREFORMED ARMOR RODS
3. DESIGNED FOR TAP AND PARALLEL CONNECTIONS
4. ASSEMBLED WITH HIGH STRENGTH STAINLESS STEEL BOLTS AND FLAT WASHERS
5. ALL CONDUCTOR CONTACT SURFACES HAVE SERRATED GROVES TO PROVIDE INCREASED CONDUCTOR CONTACT AND IMPROVE MECHANICAL PERFORMANCE
6. FOR ALUMINUM TO COPPER APPLICATIONS, IT IS RECOMMENDED TO INSTALL THE ALUMINUM CONDUCTOR ABOVE THE COPPER CONDUCTOR TO MINIMIZE CORROSION
7. FOR FACTORY APPLIED OXIDE INHIBITOR, SUFFIX CATALOG NUMBER WITH "-BF"
8. FOR TIN PLATING ON BODY AND CLAMP, SUFFIX CATALOG NUMBER WITH "-TN"
9. CONFORMS TO ANSI C119.4, CLASS AA CURRENT, CLASS 3 TENSION WHEN PROPERLY INSTALLED
10. ALL DIMENSIONS IN INCHES UNLESS OTHERWISE SPECIFIED
11. APPROX. WEIGHT: 0.839 LB

NO.	ECN	DATE
REVISIONS		

QTY.	PT.	NAME OR DESCRIPTION
		ALUM. PARALLEL CLAMP ASS'Y
REF. DWG'S: 5E16-97156		H:\H:\5E16\97156_C
DRAWN BY: QJB		DATE: 2/16/2023
SCALE: 1:1		INTERPRET PER ASME Y14.5-2009
SIZE: B		FILE: 5E16
DWG. NO. PCAA-27		REV. -
229 WATERFORD STREET EDINBORO, PA 16412 USA		