

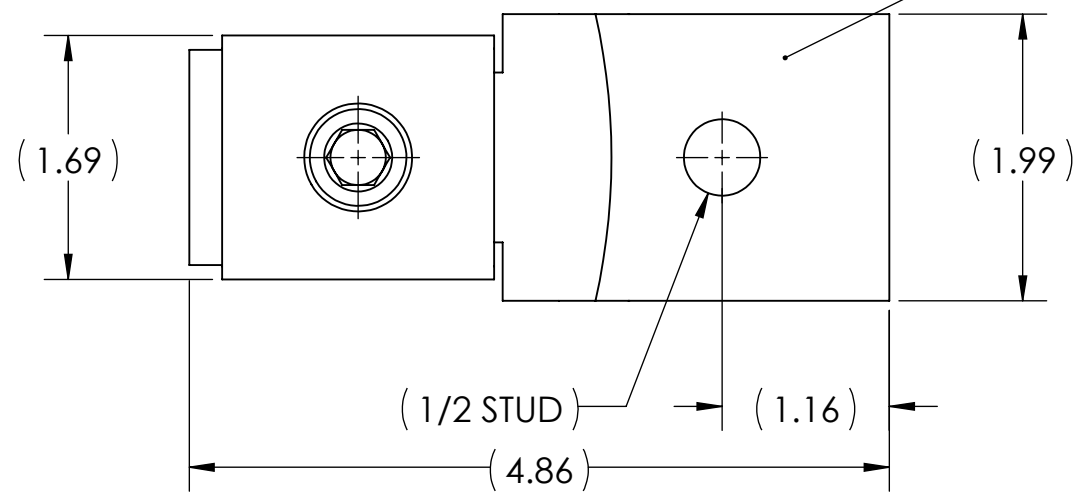

DWG. NO.

SLU-650

REV. 5



METAL STAMPING TO READ:

1. PUC
2. SLU-650
3. 1000-600
4. CU
5. 

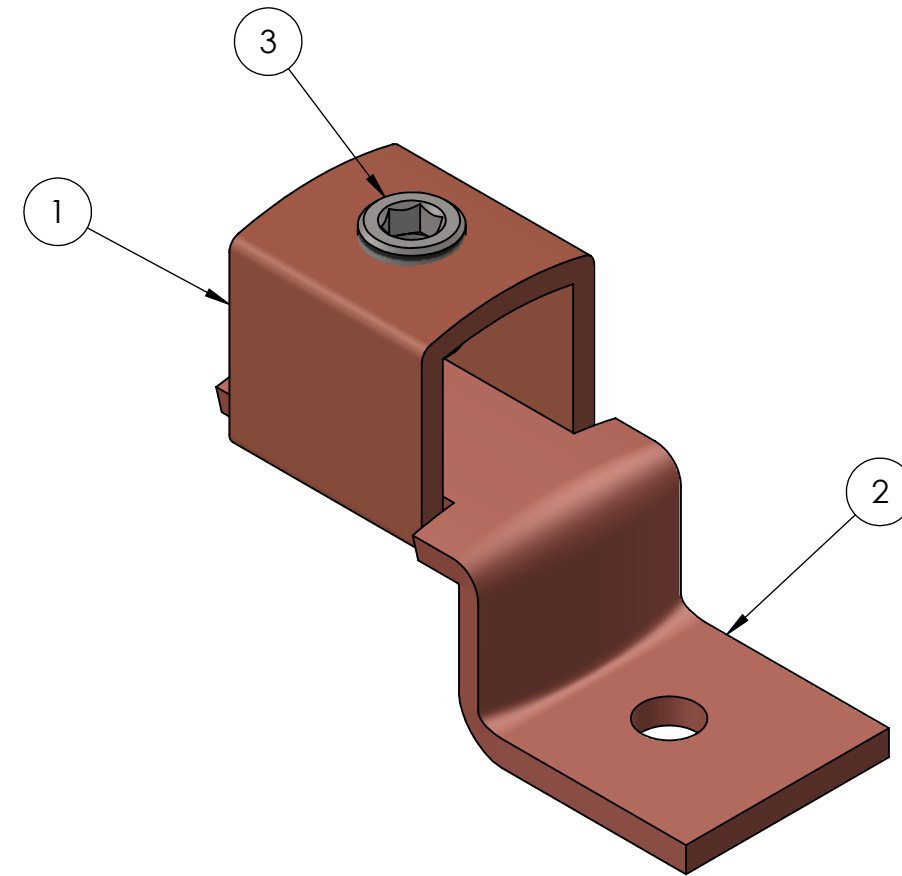
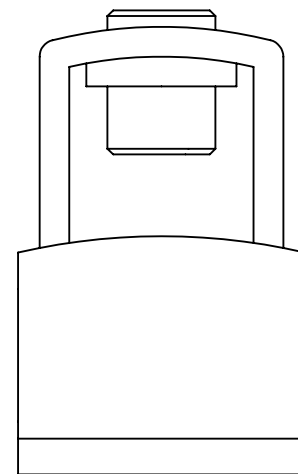
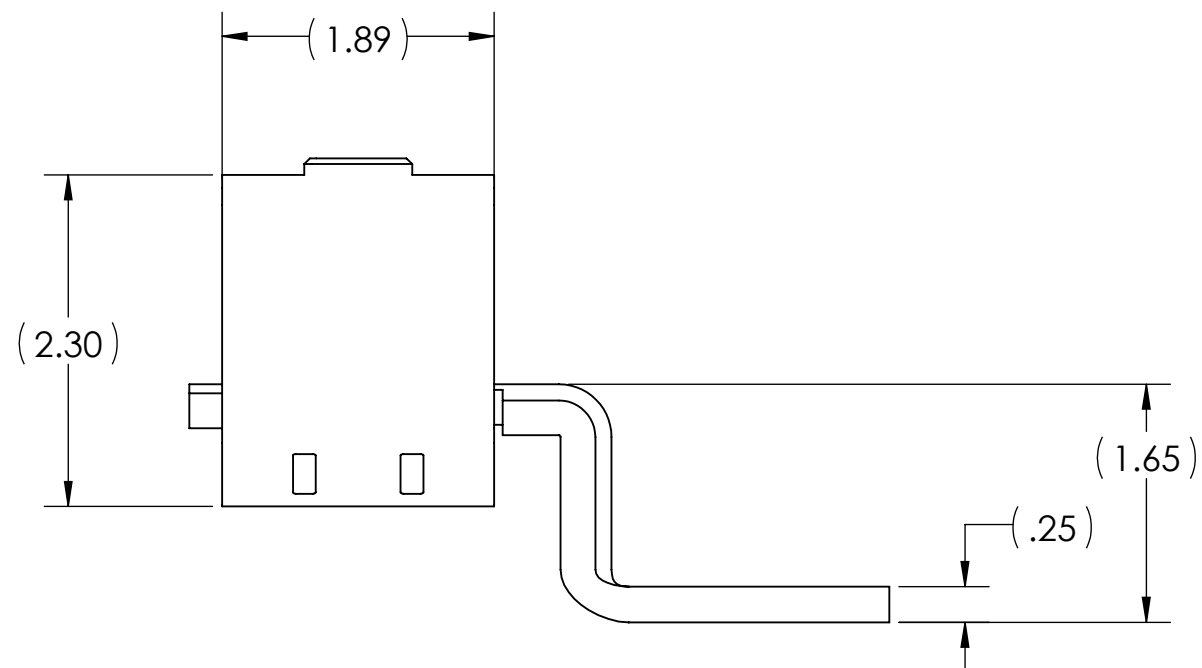

NOTES:

1. FOR TIN PLATING, SUFFIX CATALOG NUMBER WITH "-TN"
2. ALL DIMENSIONS IN INCHES UNLESS OTHERWISE SPECIFIED
3. cULus LISTED PER UL486A-B FOR POWER APPLICATIONS UP TO 90°C
4. cULus LISTED PER UL467 FOR GROUNDING, BONDING, AND DIRECT BURIAL
5. INSTALLATION TORQUE: 375 IN•LB
6. HEX SIZE: 3/8
7. APPROX. WEIGHT: 1.671 LB



NO.	ECN	DATE
5	12235	2/22/2023
4	12152	10/29/2021
3	11860	7/2/2019
2	11745	4/4/2018
1	11705	8/24/2017

QTY.	PT.	NAME OR DESCRIPTION
1	3	SET SCREW, STEEL, BLUE ZINC PLATED
1	2	LUG TONGUE, COPPER
1	1	LUG BODY, COPPER
COPPER MECHANICAL LUG		
for 1000-600 MCM COPPER CONDUCTORS		
REF. DWG'S: 5506-55833		H:\5506\SLU-650
		DRAWN BY: CLT DATE: 7/19/2023 CHK'D: QJB
229 WATERFORD STREET EDINBORO, PA 16412 USA		SCALE: 3:4 INTERPRET PER ASME Y14.5-2009 FILE: 5506
DWG. NO.	SLU-650	REV. 5